

Hydra-Cell[®]

Seal-less Pumps

Versatile, Reliable Pumps for a Wide Range of Applications



D04 Series

- Pumps the full spectrum of low-to-high viscosity fluids.
- Features a seal-less design and horizontal disk check valves that enable the pump to handle abrasives and particulates that might damage or destroy other types of pumps.
- Simple, compact design reduces initial investment and lowers maintenance costs.
- Operational efficiencies reduce energy costs.
- Able to run dry without damage (or additional maintenance) to the pump in case of accident or operator error.
- Tolerates non-ideal operating conditions.
- Minimizes maintenance and downtime because there are no mechanical or dynamic seals, packing, or cups to leak, wear, or replace.

D04 Series

Maximum Flow Rate: 2.9 gpm (11.2 l/min)

Maximum Pressure: 2500 psi (172 bar) for Metallic Pump Heads



D04 shaft-driven with 316L Stainless Steel pump head.



D04 shaft-driven with Brass pump head.

D04 Series Performance

Capacities

Flow

Model	Max. Input rpm	Max. Flow @ 2500 psi (172 bar)	
		gpm	l/min
D04-X	1750	2.9	11.2
D04-E	1750	2.0	7.7
D04-S	1750	1.6	6.2

Pressure

Maximum Inlet Pressure
500 psi (34 bar)

Maximum Discharge Pressure
2500 psi (172 bar)

Performance and specification ratings apply to D04 configurations unless specifically noted otherwise.

Maximum Flow at Designated Pressure

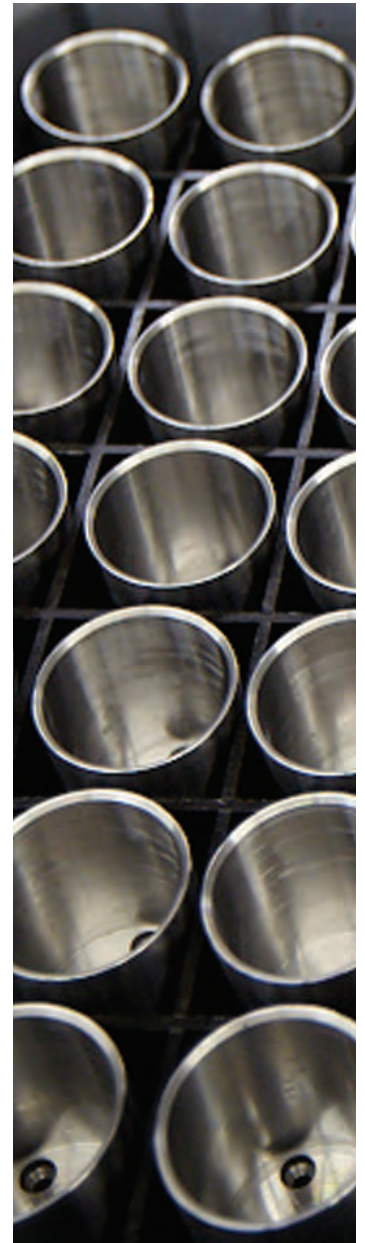
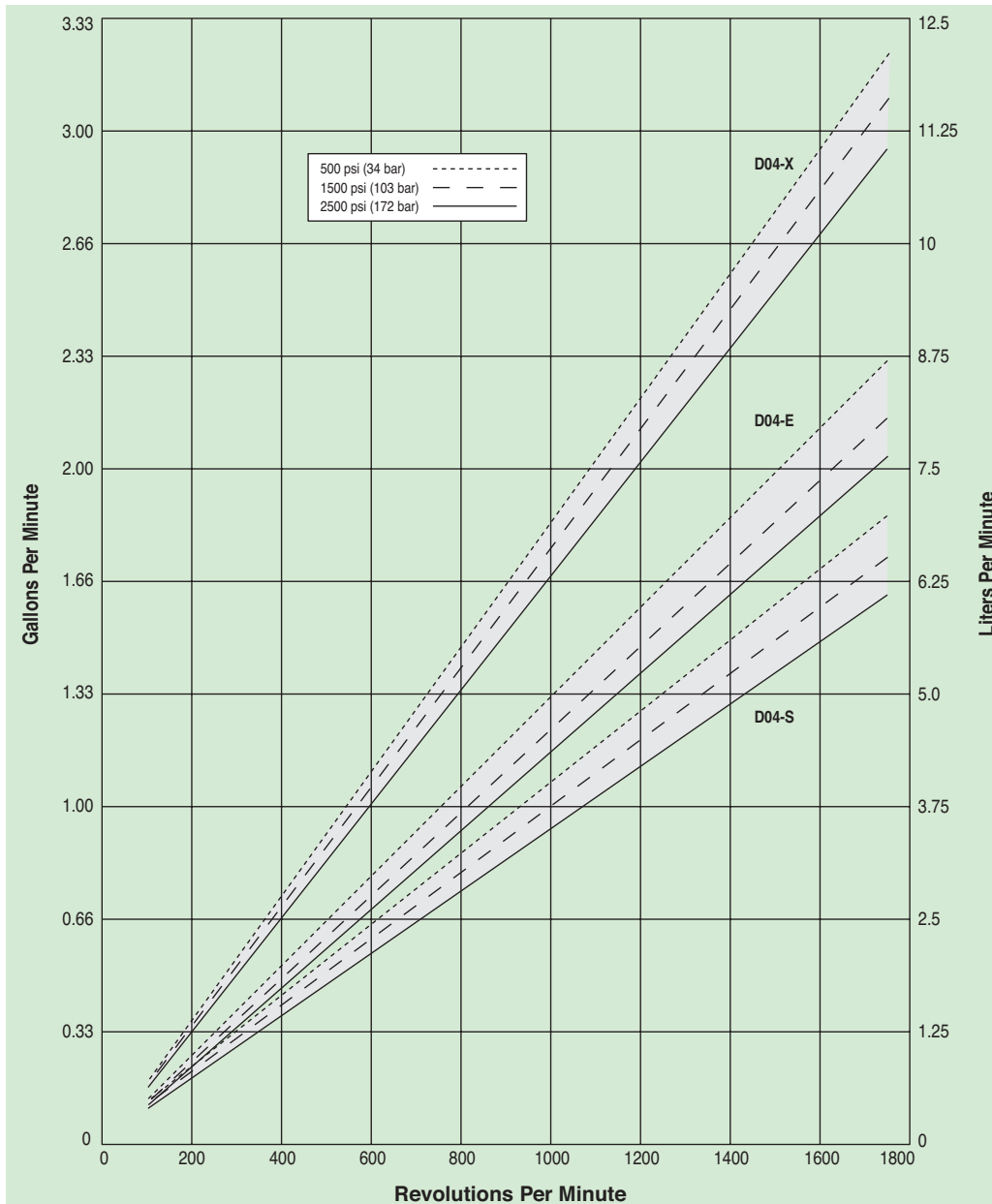

D04 Series Specifications

Flow Capacities @2500 psi (172 bar)

Model	rpm	gpm	l/min
D04-X	1750	2.95	11.16
D04-E	1750	2.04	7.71
D04-S	1750	1.63	6.19

Delivery

Model	gal/rev		
	@500 psi (34 bar)	@1500 psi (103 bar)	@2500 psi (172 bar)
D04-X	0.0019	0.0018	0.0017
D04-E	0.0013	0.0012	0.0012
D04-S	0.0011	0.0010	0.0009

Model	liters/rev		
	@500 psi (34 bar)	@1500 psi (103 bar)	@2500 psi (172 bar)
D04-X	0.0070	0.0067	0.0064
D04-E	0.0050	0.0047	0.0044
D04-S	0.0041	0.0039	0.0035

Maximum Discharge Pressure

Metallic Heads: 2500 psi (172 bar)

Maximum Inlet Pressure 500 psi (34 bar)

Maximum Operating Temperature

Metallic Heads: 250 °F (121 °C) - Consult factory for correct component selection for temperatures from 160 °F (71 °C) to 250 °F (121 °C).

Maximum Solids Size 200 microns

Inlet Port 1/2 inch NPT
600lb ANSI RF flange

Discharge Port 1/2 inch NPT
2500lb ANSI RF flange

Shaft Diameter 7/8 inch (22.2 mm)

Shaft Rotation Reverse (bi-directional)

Bearings Precision ball bearings

Oil Capacity 1.1 US quarts (1.05 liters)

Weight 37 lbs. (16.8 kg)

Net Positive Suction Head (NPSHr)

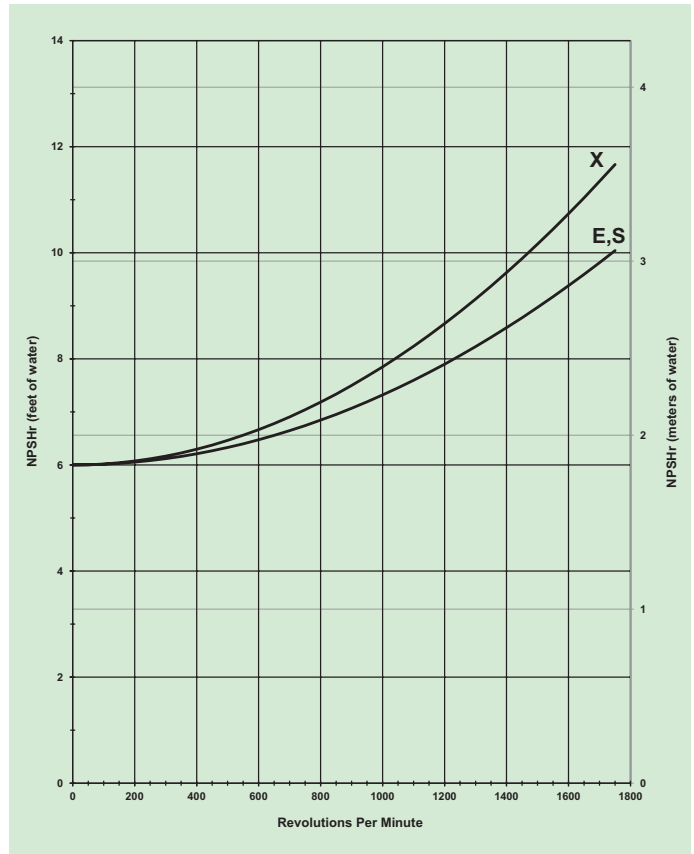

Self-priming:

Each Hydra-Cell pump has different lift capability depending on model size, cam angle, speed, and fluid characteristics. To ensure that your specific lift characteristics are met, refer to the inlet calculations regarding friction, and acceleration head losses in your Hydra-Cell Installation & Service Manual. Compare those calculations to the NPSHr curves above.

Calculating Required Power

$$\frac{6 \times \text{rpm}}{63,000} + \frac{\text{gpm} \times \text{psi}}{1,460} = \text{electric motor hp}$$

$$\frac{6 \times \text{rpm}}{84,428} + \frac{\text{l/min} \times \text{bar}}{511} = \text{electric motor kW}$$

When using a variable frequency drive (VFD) controller, calculate the hp or kW at minimum and maximum pump speed to ensure the correct hp or kW motor is selected. Note that motor manufacturers typically de-rate the service factor to 1.0 when operating with a VFD.

D04 Series Representative Drawings

D04 Models with Metallic Pump Head Inches (mm)

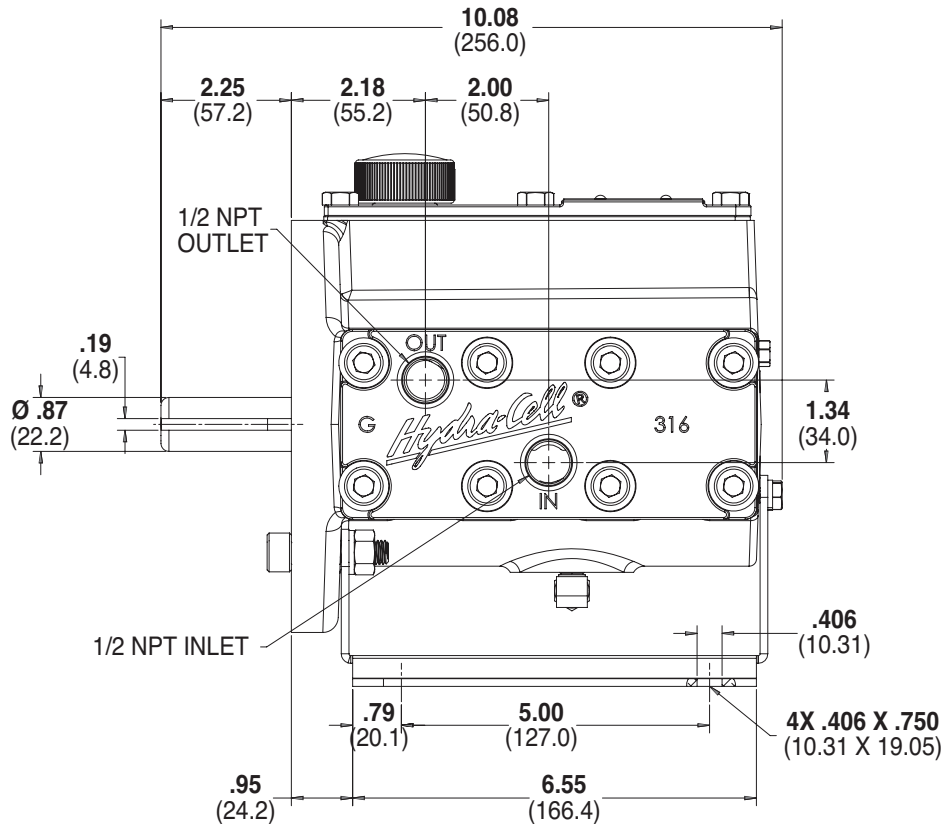
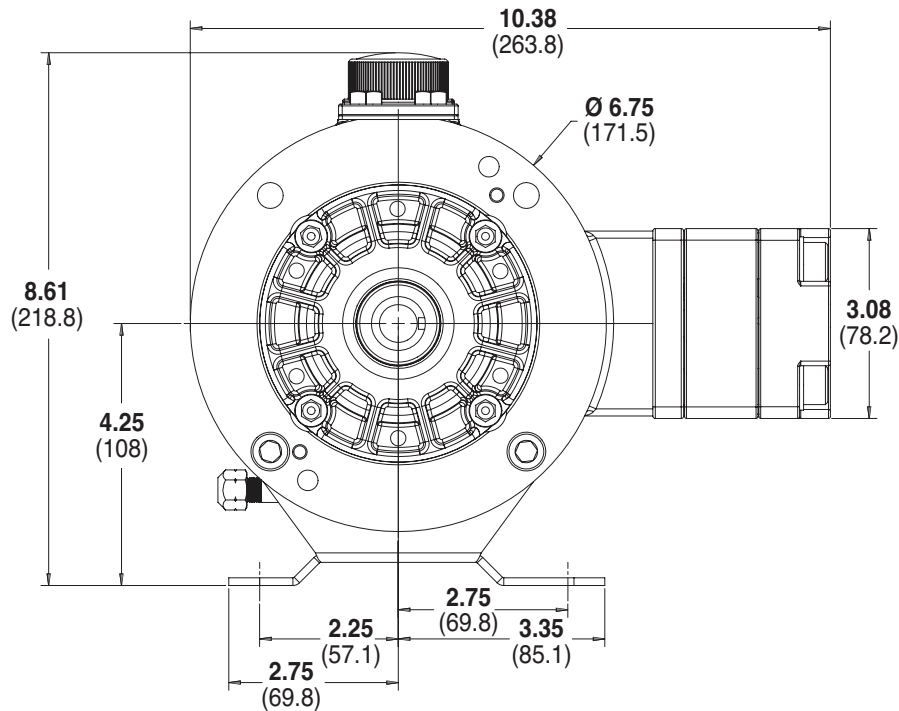

Note: Contact factory for additional drawings of specific models and configurations.

D04 Series **Adapters/Valves**

Pump/Motor Adapter Inches (mm)

Part Number: A04-001-I202

Must be ordered separately for D04 models for use with 56C, I43TC and I45TC frame motors.

Metric adapter available - consult factory.

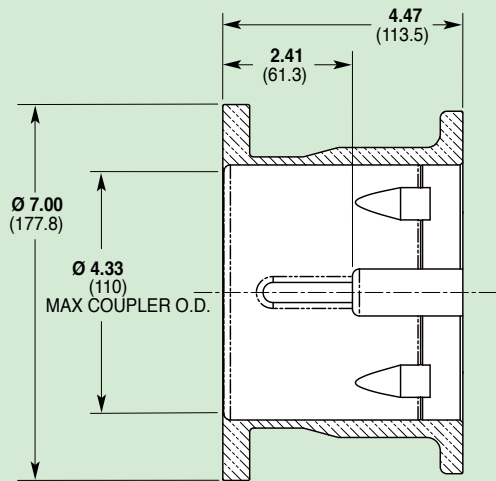

Part Number: A04-002-I202

Must be ordered separately for D04 models for use with I82TC, I84TC, 2I3TC and 2I5TC frame motors.

Metric adapter available - consult factory.

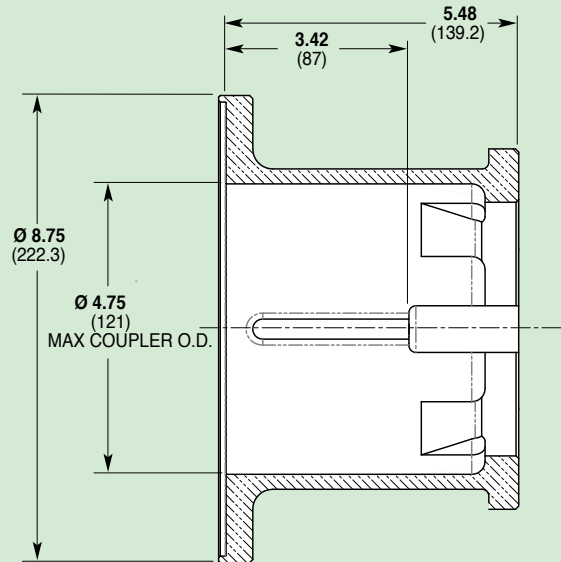

Valve Selection

A seal-less C62 Pressure Regulating Valve is recommended for Hydra-Cell D04 pumping systems, especially for high-pressure requirements or when handling dirty fluids.



For complete specifications and ordering information, consult the Hydra-Cell Master Catalog.

D04 Series **How to Order**

Ordering Information

1	2	3	4	5	6	7	8	9	10	11	12
---	---	---	---	---	---	---	---	---	----	----	----

A complete D04 Series Model Number contains 12 digits including 9 customer-specified design and materials options, for example: D04SABTHFECG.

Digit	Order Code	Description
1-3	D04	Pump Configuration Shaft-driven (NPT Ports)* *Pump/motor adapters ordered separately. See previous page.
4	X	Hydraulic End Cam Max 2.9 gpm (11.2 l/min) @ 1750 rpm
	E	Max 2.0 gpm (7.7 l/min) @ 1750 rpm
	S	Max 1.6 gpm (6.2 l/min) @ 1750 rpm
5	A	Pump Head Version NPT Ports
6	B	Pump Head Material Brass
	R	304 Stainless Steel
	S	316L Stainless Steel
	T	Hastelloy C
7	E	Diaphragm & O-ring Material EPDM (requires EPDM-compatible oil - Digit 12 oil code J)
	G	FKM
	J	PTFE
	P	Neoprene
	T	Buna-N
8	D	Valve Seat Material Tungsten Carbide
	H	17-4 Stainless Steel
	N	Nitronic
	T	Hastelloy C
9	D	Valve Material Tungsten Carbide
	F	17-4 Stainless Steel
	N	Nitronic 50
	T	Hastelloy C
10	E	Valve Springs Elgiloy
	S	316L Stainless Steel
	T	Hastelloy C

Digit	Order Code	Description
11		Valve Spring Retainers
	C	Celcon
	H	17-7 Stainless Steel
	M	PVDF
	P	Polypropylene
	T	Hastelloy C
	Y	Nylon
12		Hydra-Oil
	G	5W30 cold-temp severe-duty synthetic oil
	J	EPDM-compatible oil
	K	Food-contact oil

Consult the Hydra-Cell Master Catalog for:

- Motors, bases, couplings and other pump accessories
- Hydra-Oil selection and specification information
- Design considerations, installation guidelines, and other technical assistance in pump selection

Hydra-Cell[®]

Seal-less Pumps

Wanner Engineering, Inc.

World Headquarters & Manufacturing

Wanner Engineering, Inc.
1204 Chestnut Avenue,
Minneapolis, MN 55403 USA
Phone: 612-332-5681 • Fax: 612-332-6937
Toll-Free Fax (USA): 800-332-6812
Email: sales@wannereng.com
www.Hydra-Cell.com

207 US Highway 281
Wichita Falls, TX 76310 USA
Phone: 940-322-7111
Toll-Free: 800-234-1384
Email: sales@wannereng.com
www.Hydra-Cell.com

Latin American Office

R. Álvaro Anes, 150 Bairro Campestre
Santo André/São Paulo, Brazil - CEP 09070-030
Phone: +55 (11) 4081-7098
Email: mmagoni@wannereng.com
www.Hydra-Cell.com

Wanner International Ltd.

Wanner International, Ltd.
Hampshire - United Kingdom
Phone: +44 (0) 1252 816847
Email: sales@wannerint.com
www.Hydra-Cell.eu

Wanner Pumps Ltd.

Wanner Pumps, Ltd.
Kowloon - Hong Kong
Phone: +852 3428 6534
Email: sales@wannerpumps.com
www.WannerPumps.com

Shanghai - China
Phone: +86-21-6876 3700
Email: sales@wannerpumps.com
www.WannerPumps.com

